

Operation and Maintenance Manual

Sterile Storage Cabinet

SSC4500DX

99C0177-00-Standard unit
94C0078-00 Ceiling Duct Kit
91C0191-00 0-10VDC Retransmit Kit
91C0192-00 UV-C Light Kit Air Side



AIR INNOVATIONS

7000 Performance Drive
Syracuse, NY 13212

Phone (315) 452-7400
Fax (315) 452-7420
airinnovations.com

Table of Contents

1.0 Sterile Storage Cabinet System Overview	3
2.0 Safety Precautions	6
3.0 Cabinet Storage	7
4.0 Acceptance and Unpacking the SSC4500DX	8
5.0 Unit Views and Labels.....	9
6.0 Installation and Initial Startup	11
7.0 User Interface, Displays and Alarms	14
8.0 Keyless Lock	17
9.0 Field Terminations.....	20
10.0 Maintenance.....	21
11.0 Troubleshooting.....	28
12.0 Warranty.....	29

1.0 Sterile Storage Cabinet System Overview

The SSC 4500DX Sterile Storage Cabinet is designed to store and to protect medical equipment and supplies. The internal chamber volume will be maintained at the following conditions: 66-72°F, 20-60% RH (max dew point 57°F), and a minimum internal positive pressure + 0.01 In-H₂O or greater to maintain ISO Class 5 conditions. The ambient temperature ranges from 60-82°F and 10%-50% RH. During normal use and operation, the cabinet will be accessed (door opened) an unlimited number of times per day or per hour to either load or retrieve medical supplies. The cabinet is supplied with (5) removable shelves that are fully adjustable. They easily removeable for cleaning.

Dimensions and Views

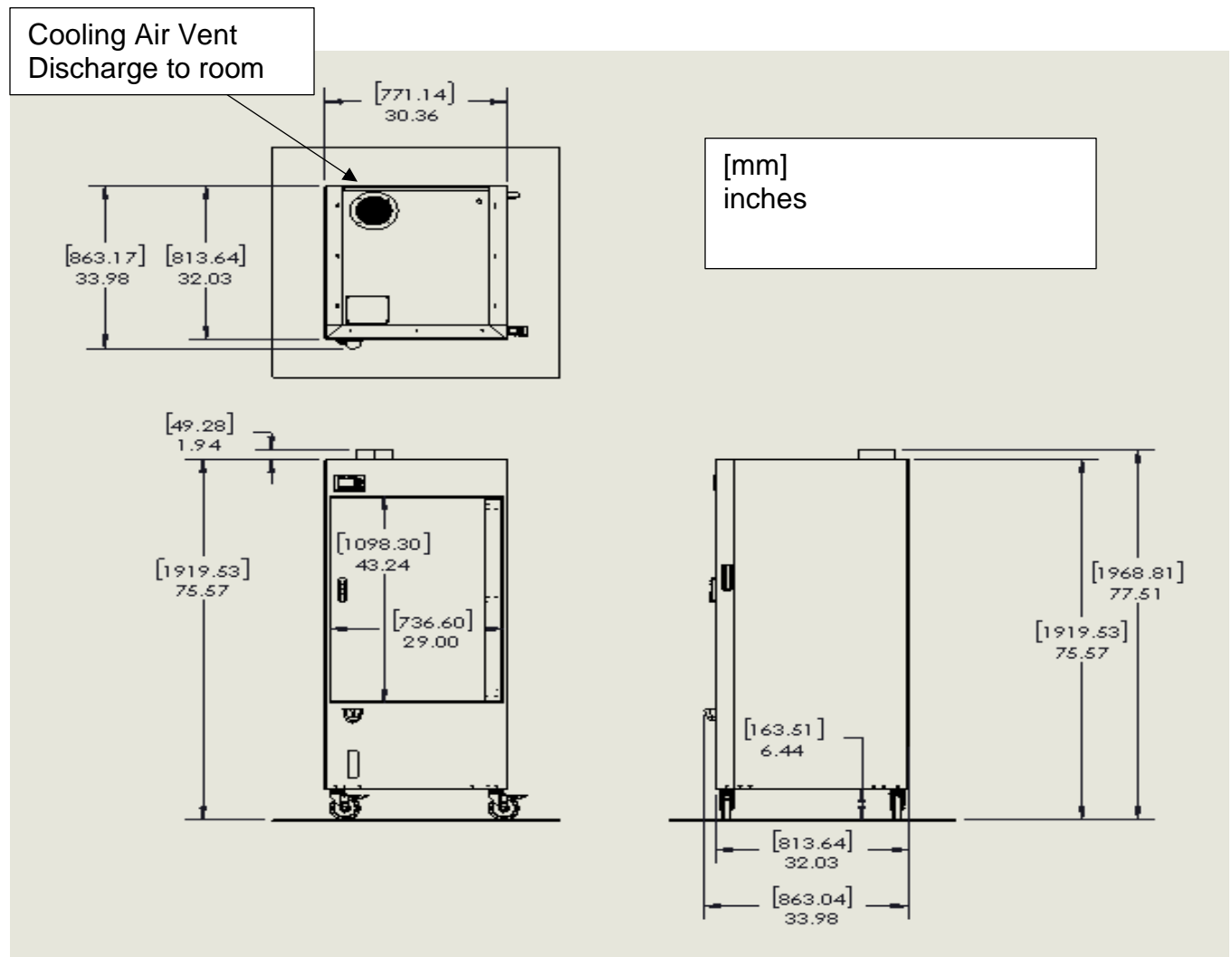

Sequence Of Operation

Initial Power Up:

Upon powering up, there is a 15 second ON-DELAY timer. This allows the LOGO PLC controller to power up, to perform its internal diagnostics, to validate all sensors, and to confirm all inputs are reading and functioning properly. The main display screen will be established and display the following: Date, Time, Temperature (°F), Humidity % RH, and Pressure "WC.

Establish Continuous Air Circulation and Positive Pressure:

Once the initial power-up timer has expired, the evaporator fan will be energized, it will run continuously so long as the cabinet is powered. A 30 second ON-DELAY timer will be activated; this will allow sufficient time to establish air recirculation and positive internal pressure.

The internal cabinet pressure will be continuously monitored, displayed, and alarmed. The minimum internal pressure is 0.01"WC, this value can be adjusted. If the internal pressure drops below the pressure limit, a 60-second ON-DELAY timer will be activated. After 60 seconds, if the pressure is not at or above the 0.01"WC, an alarm will be triggered. The display screen will change to red and the alarm condition will be displayed along with the date of the alarm, the time, and corrective action. The REMOTE ALARM RELAY will be energized during this alarm condition. Once the pressure is re-established above the 0.01"WC, the alarm relay will de-energize and the display will clear and return to the default screen. This condition typically occurs when hospital personnel open the cabinet door to supply or retrieve medical equipment from the cabinet; when the door is open, the internal pressure goes to zero. This function will also detect a failed evaporator fan or a heavily loaded HEPA filter that needs replacement.

Temperature Control:

The internal cabinet temperature will be monitored and compared to the TEMPERATURE SET POINT (range 65-75°F user selectable default 69°F). The temperature will be controlled by pulsing of a 500W heater by a solid-state relay (SSR).

The following safeties will be incorporated to continuously protect both the compressor and heater. An HPS (high pressure switch) will continuously monitor the discharge pressure of the compressor and open at a predetermined value. If the HPS is open, the compressor/condenser fan will be de-energized. The display screen will change to red and the alarm condition will be displayed along with the date, the time of the alarm, and corrective action. The REMOTE ALARM RELAY will be energized during this alarm condition. An HTCO (auto re-set high temperature cutoff) will continuously monitor the air temperature in the evaporator exit chamber. If the HTCO is open, the heater output will immediately be de-energized until the switch closes. The display screen will change to red and the alarm condition will be displayed along with the date, the time of the alarm, and corrective action. The REMOTE ALARM RELAY will be energized during this alarm condition.

The Compressor/Condenser fan will operate continuously to maintain a constant off-coil temperature for dehumidification control. The 500W heater will be modulated (PWM) based on a PID-type loop controller specific to the LOGO controller. If the measured temperature exceeds the TEMPERATURE SET POINT plus 3°F, a 120 second timer will be initiated. If after 120 seconds the temperature has not dropped below the TEMPERATURE SET POINT plus 1 °F, the screen will change to red and the alarm condition will be displayed. The REMOTE ALARM RELAY will be energized. Once the measured temperature drops to TEMPERATURE SET POINT plus 1 °F, the alarm relay will de-energize and the display will clear.

Humidity Control:

The internal humidity will be continuously monitored, displayed, and alarmed. The interior of the cabinet shall be maintained between a maximum of 60% RH and a minimum of 20% RH. There are typically (2) distinct processes involved in the control of RH. If the RH is high, dehumidification is required; if the RH is low, moisture is added to the airstream. The refrigeration cassette of the cabinet is designed to operate with a 55°F evaporator leaving-air temperature, IE a dew point temp or maximum RH of 60%. Therefore, from a control point of view, there is nothing to manipulate to lower the humidity by design.

The humidity level of the cabinet has a minimum value of 20%. This is a user-defined value that ranges from 20% to 40% with a default value of 20%. If the RH is below the MIN RH VALUE SETPOINT, humidification is required. The physical hardware to raise the humidity involves several mechanical components: 1) A water tank with LOW LEVEL SWITCH, and WATER PUMP. 2) A condensate pan with HIGH LEVEL SWITCH, SOLENOID VALVE, and HEATER.

If the measured RH value goes above 60% RH, the display screen will change to red and the alarm condition will be displayed along with the date of the alarm, the time, and corrective action. The REMOTE ALARM RELAY will be energized during this alarm condition.

If the RH drops to an RH value that is below the MIN RH SETPOINT, the humidification will be automatically initiated to raise the internal RH value to the MIN RH SETPOINT plus 2%. The LOW LEVEL SWITCH in the water tank will be verified, a 10-minute ON-DELAY timer and the condensate pan HEATER will be activated to pre-heat the pan before water is added. Once the timer has expired, water can be added to the pan. The HIGH LEVEL SWITCH verifies that there is no excess water in the pan. Water can now be added to the pan. A PULSE RELAY is activated with an ON-TIME of 1-sec and an OFF-TIME of 10 min. During the 1-second on time, both the WATER PUMP and the SOLENOID VALVE are activated. This cycle will repeat until the internal cabinet RH is at the MIN RH VALUE plus 2%. Once this RH value is achieved, the PULSE RELAY will be stopped and a 15 min OFF-DELAY timer will be started to completely dry out the condensate pan so there is no standing water.

The water level in the de-mineralized water storage tank is automatically verified prior to starting the humidification process. If the LOW LEVEL SWITCH is activated, the display screen will change to amber and the alarm condition will be displayed along with the date of the alarm, the time, and corrective action. The REMOTE ALARM RELAY will be energized during this alarm condition. The humidification process will be delayed until the water tank is refilled.



2.0 Safety Precautions



To reduce the risk of fire, electric shock, and injury, **basic safety precautions should always be followed** when using electrical appliances.

These precautions include the following:

- Read all instructions before using the cabinet.
- To avoid potential fire or shock hazards, plug the cabinet directly into a 120V AC electrical outlet.
- Remove all packaging before use.
- Keep the cord out of heavy traffic areas to avoid potential fire hazard. NEVER put the cord under rugs, near heat registers, radiators, stoves, or heaters.
- To protect against electrical hazards, DO NOT immerse in water or other liquids.
- Close supervision is necessary when used by or near children.
- Always unplug before moving or cleaning the unit.
- To disconnect the unit, be sure to pull the plug and not the cord.
- NEVER drop or insert any objects into the openings of the unit.
- Do not operate with a damaged cord or plug. If the fan fails to operate or if the unit has been dropped or damaged in any manner, contact the manufacturer for examination and/or repair.
- This unit is to be used for its intended purpose only, as described in this manual. Any other use is not recommended by the manufacturer.
- NEVER place on a soft surface, as this could cause the unit to tip over.
- Keep unit away from heated surfaces and open flames.
- DO NOT attempt to repair or adjust any electrical or mechanical functions on this unit. Doing so may void the warranty.
- All servicing to be performed by qualified personnel only.
- NEVER use detergents, gasoline, furniture polish, paint thinner, or other household solvents to clean any part of the appliance. A damp cloth can be used.
- A static charge may be felt if the unit is not properly grounded. To avoid a static charge, plug the unit's three-prong plug into a grounded outlet, or properly install a ground adapter (see PLUG SAFETY).
- This cabinet should be used only in an environmentally controlled room with temperatures between 65°F and 80°F.
- Cabinet should not be stored in a location below 32°F due to potential freezing & expansion of residual water within the cabinet.

PLUG SAFETY: To reduce the risk of electric shock, THE SSC4500DX IS EQUIPPED WITH A HOSPITAL GRADE 3-PRONG PLUG, a grounding type plug that has a third (grounding) pin.

Plug into any Standard Ground outlet or a Ground Fault Circuit Interrupter (GFCI) outlet. DO NOT remove the ground pole from plug or use an adapter for grounding! DO NOT ALTER PLUG OR CORD.

3.0 Cabinet Storage

If the cabinet is not going to be used or put in long term storage at any point in time the following preparations and conditions are required.

- 1) The cabinet should be stored in an environmentally controlled area with temperatures 40F or above. The cabinet requires de-mineralized water for proper operation and there is residual water in the plumbing reservoir tubing and pump. This water must be removed, or it will freeze and damage the cabinet.
- 2) If the cabinet has been in service it should be cleaned, dried and secured prior to storage.

4.0 Acceptance and Unpacking the SSC4500DX

The SSC4500DX is shipped in a wooden crate to protect the unit from any shipping damage or impacts. If the shock detector is showing any impact or there are any visible signs of damage to the crating, reject the cabinet and file a shipping claim with the shipping company. Carefully follow the unpacking procedure below to gain access to the SSC4500DX. Dispose all shipping material in accordance with local guidelines.

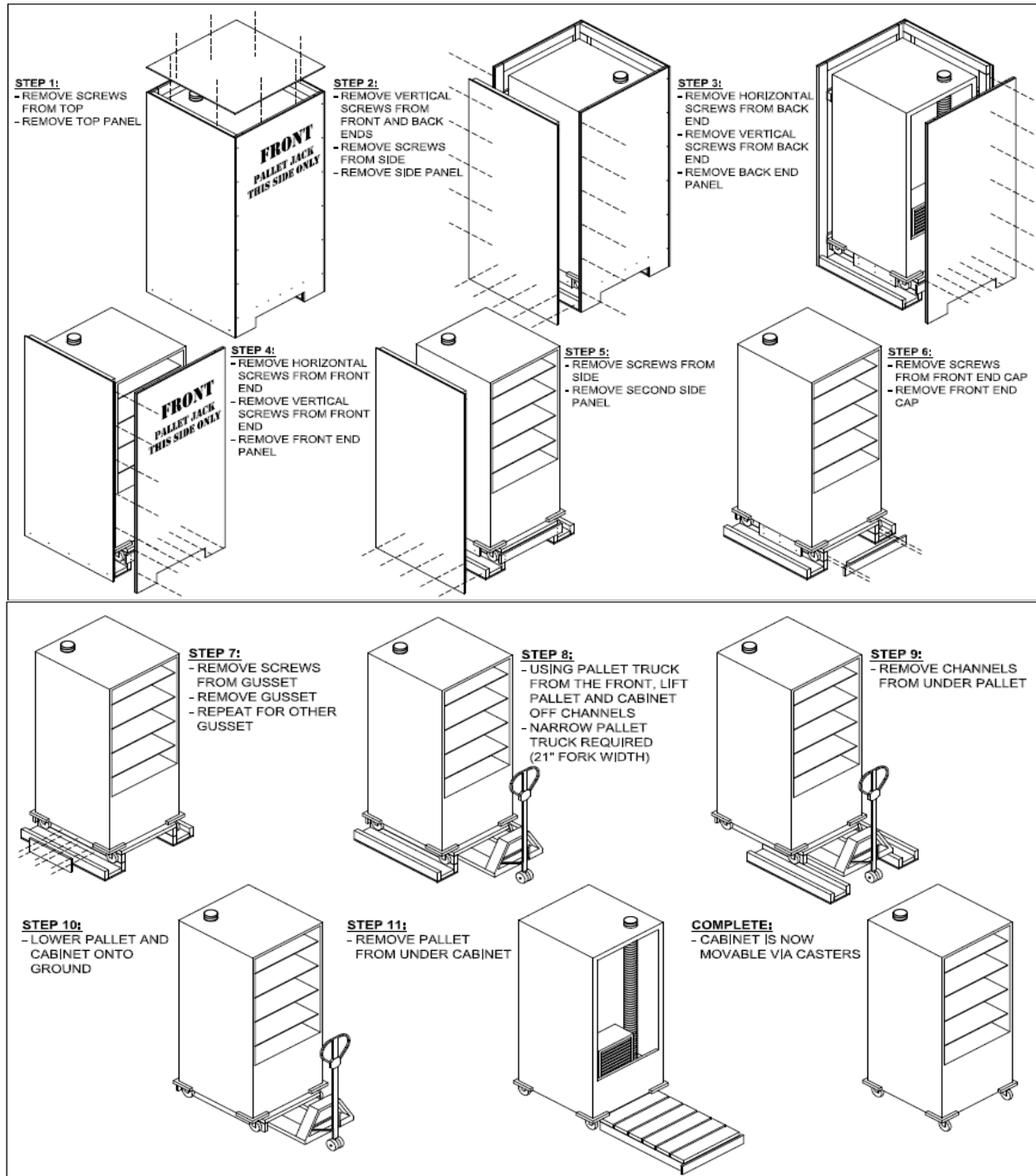

5.0 Unit Views and Labels

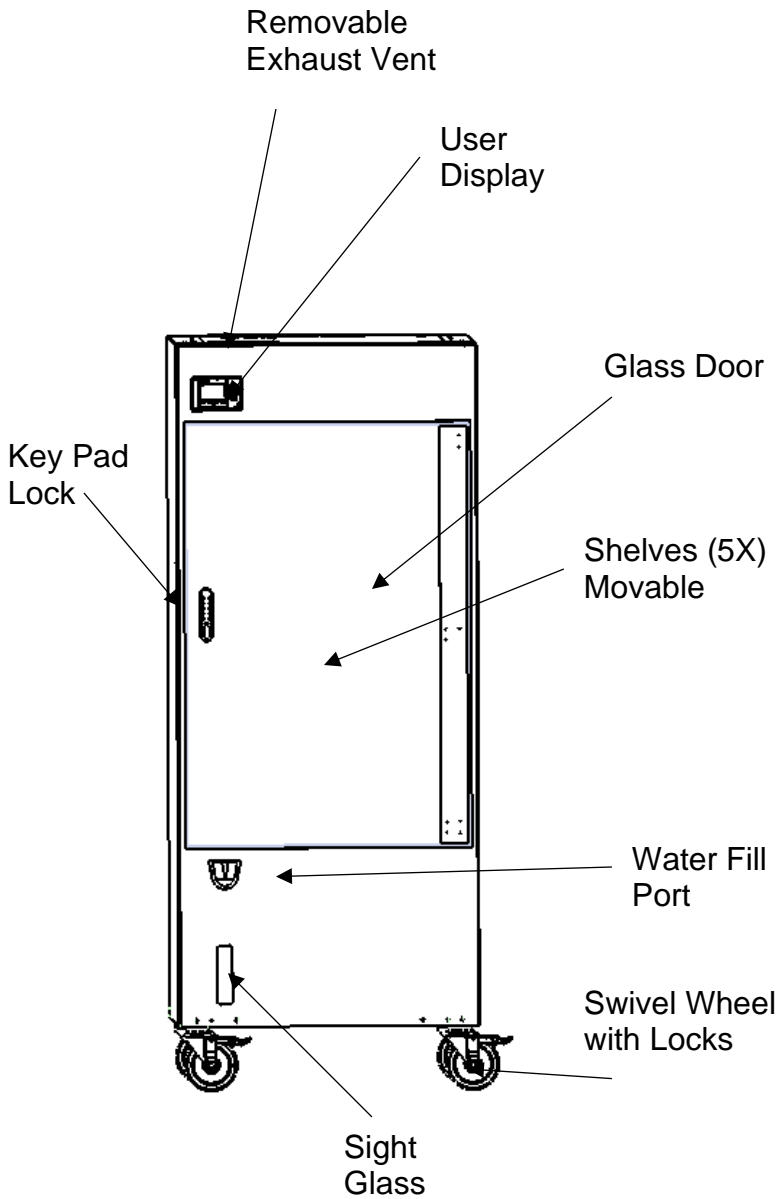

Figure: 2 Front View

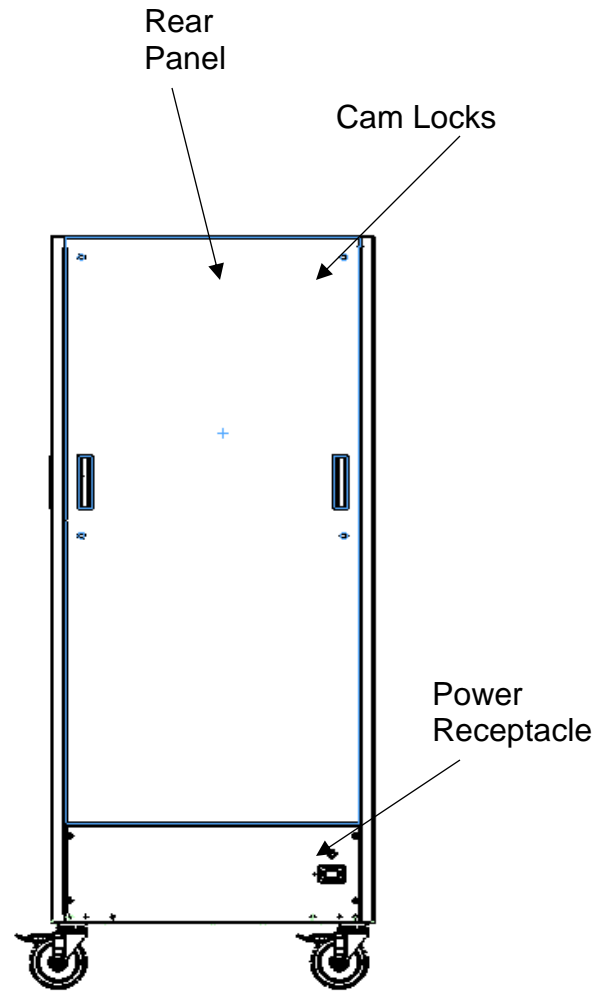

Figure: 3 Rear View

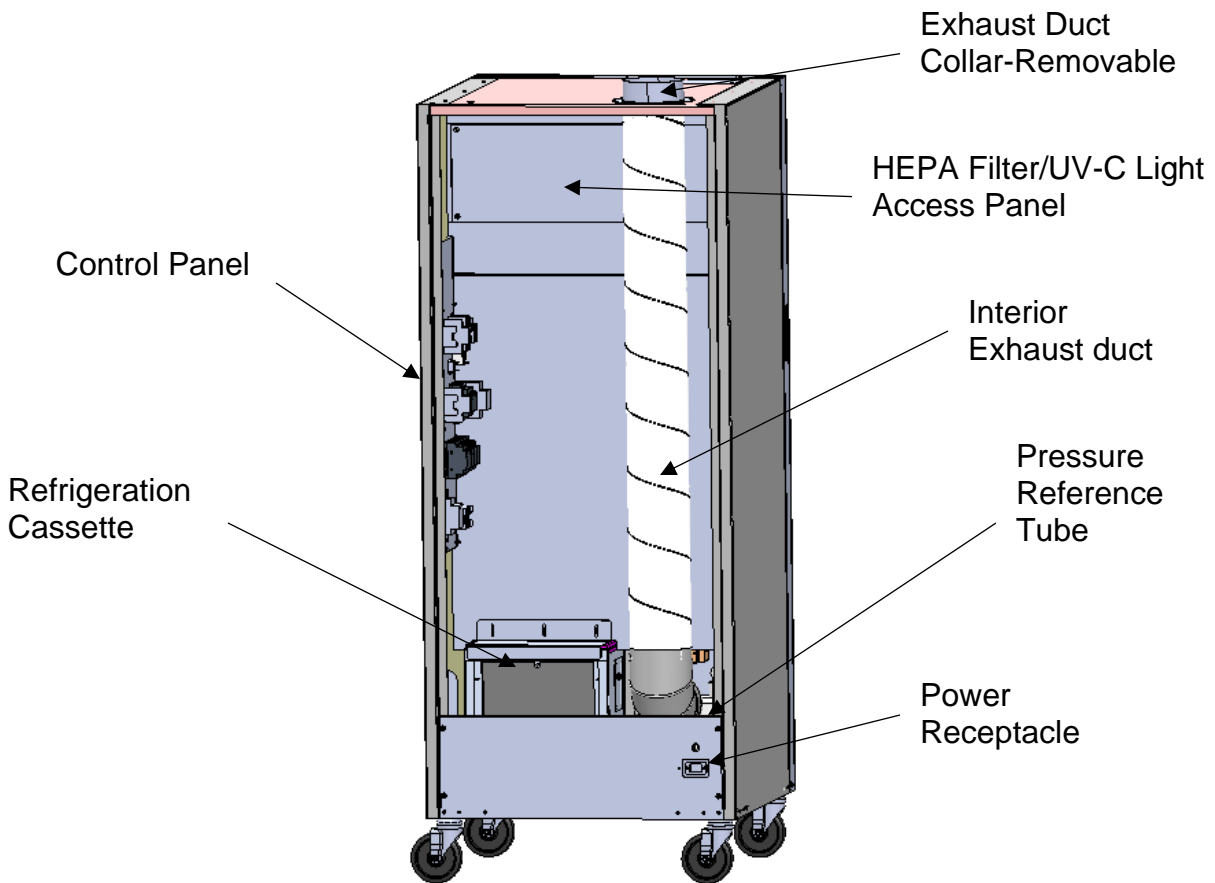

Figure 4:
Rear View Upper Panel Removed

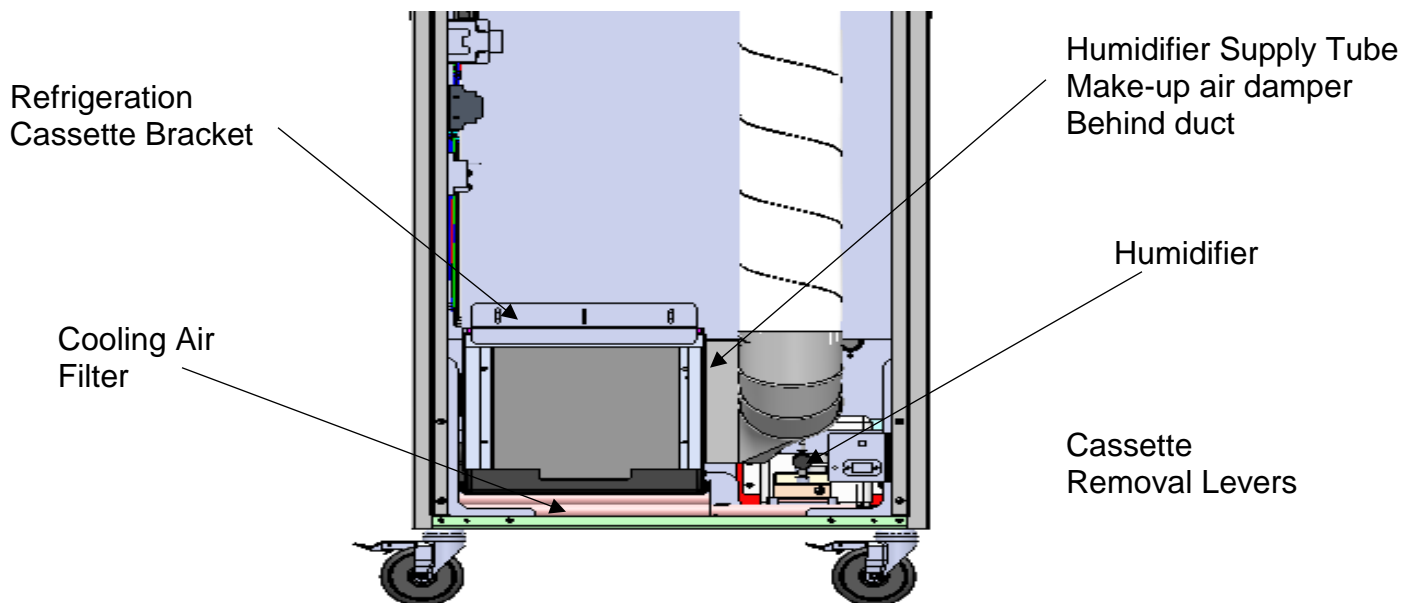

Figure 5: Rear View Lower Panel Removed



Figure 6: (5) Removable Shelves



Figure 7: Sliding shelf forward for loading and payload access.



Retention slots that support shelves.

Figure 8: Removing shelf for cleaning and adjustment.

6.0 Installation and Initial Startup

The Sterile Storage Cabinet is designed to be used in either an open exam room environment, utility closet, or alcove. The unit generates 120-130 cfm of 95-105°F air to maintain interior cabinet conditions, which is exhausted at the top surface of the unit. The cooling air intake vent is located on the bottom of the unit. Both areas should be clear and unobstructed always or the unit will fault on a high-pressure limit.

The unit has an integrated steam humidifier that will add humidity to the cabinet if the RH falls below the humidity setpoint. The humidifier should never be run dry and there are safeties to protect against this condition. The onboard water bottle must be filled. To add water, simply slide the lock to the right and lift the cap. Fill carefully while monitoring the water level through the sight glass on the front of the unit. Once full, close the cap, dry any residual water in the fill port, close the lid, and lock. If any water has spilled on the front of the unit or floor, clean and dry immediately. On very dry days (low Relative Humidity), the tank might have to be filled several times a day.

The unit can be plugged into any 120VAC 15amp wall outlet.

IMPORTANT: If plugging into a RED or backup circuit, consult with the facilities manager.

The unit will power up and perform a self-diagnostic on the controls and sensors. After a 30-sec delay, the evaporator fan will start and provide air flow to the interior of the cabinet, establishing a positive pressure. The refrigeration system will energize 30 seconds later and start the process of conditioning the cabinet.

The unit's internal conditions are pre-set to nominal values. The unit must be run for 24hrs prior to loading any equipment or supplies. The cabinet must acclimate to the local conditions and thermally stabilize. The temperature and humidity will fluctuate during this 24-hour period.

Utility Closet or Alcove Installation

When the unit is installed in a utility closet or alcove, it is critical to have sufficient air flow to properly cool the unit. The space around the bottom of the unit must be free and clear to allow room air to enter through the bottom of the unit. The utility closet or alcove must be vented to a large open-air space above the ceiling or other open space per facility guidelines. The optional Ceiling Exhaust Kit can be used. The exhaust vent on the top of the unit will accept standard 6" flex duct not to exceed 20 ft in length. It is critical to ensure there are no sharp bends, kinks or crushed duct, as this will affect the performance of the unit.

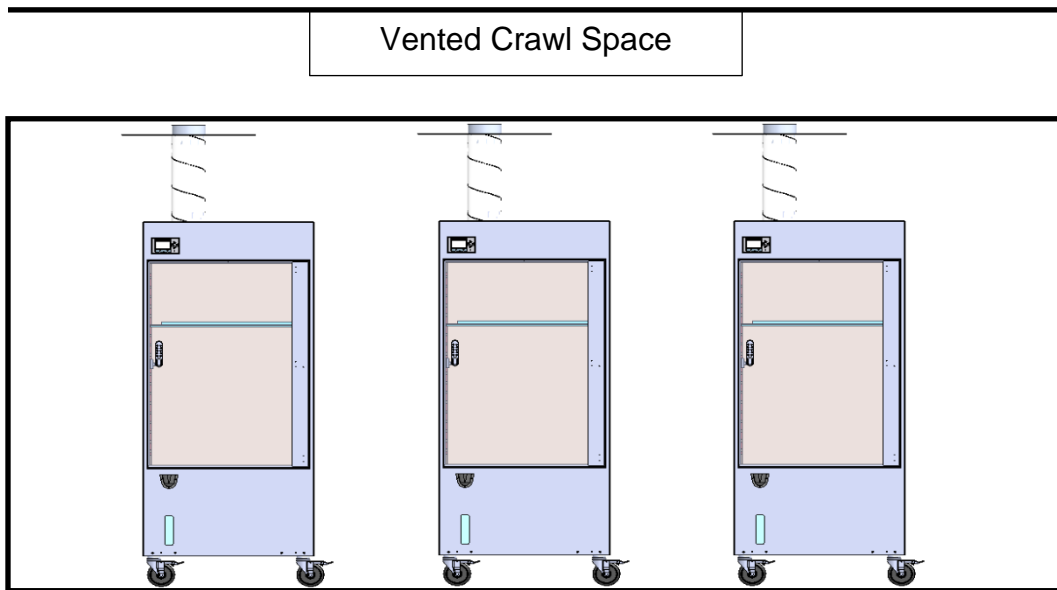
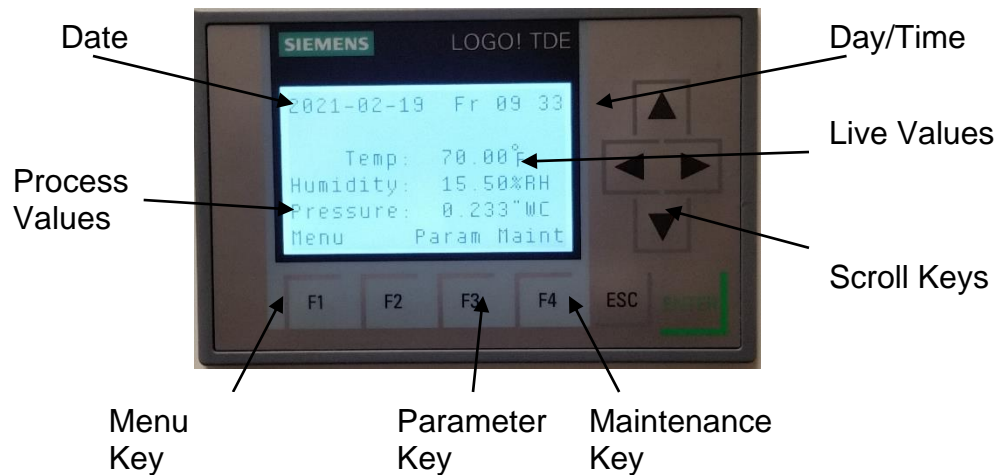

Figure 9: (3) Units installed in closet.

7.0 User Interface, Displays and Alarms

Main Display Screen



The display screen will display live values of Temperature (Deg. F), Humidity (%RH) and internal pressure ("WC). The Function Keys at the bottom of the display will access features and operating parameters.

Menu Screen

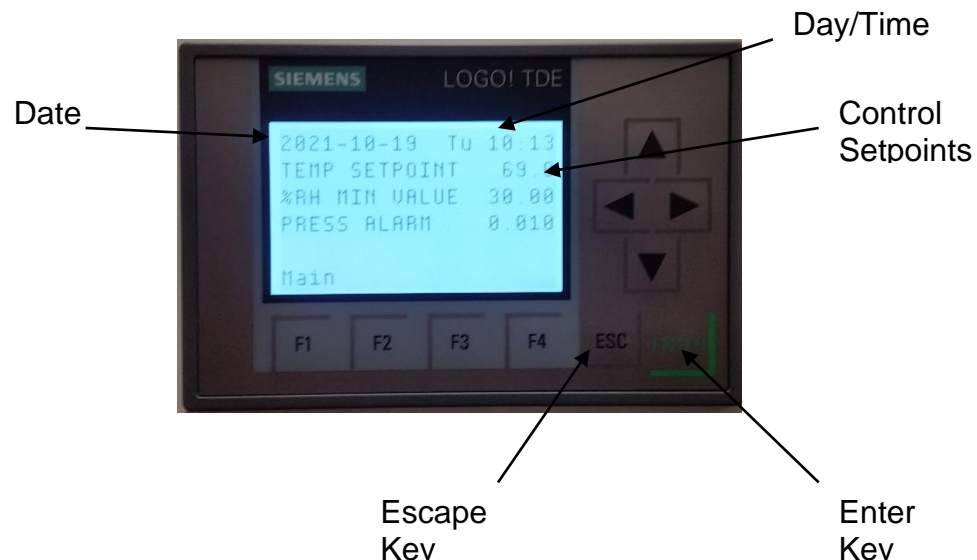

The Menu screen is accessed by depressing the F1 key under the display. There are three field-adjustable parameters on the cabinet: Temperature, Humidity and Internal Pressure Alarm Limit. To adjust the set points, press the escape key until the field highlights (black). Use the arrow keys to maneuver to the variable and select enter. The value can now be changed. Select enter again to store value, then escape to close the adjustment. Use F4 to return to the main screen.

NOTE: For VA Hospitals the Temp Setpoint is 69 Def F.

Parameter Screen

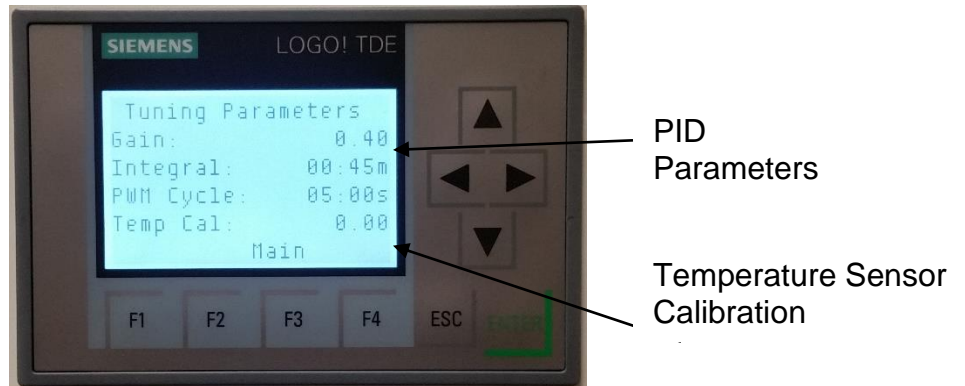

PID
Parameters

Temperature Sensor
Calibration

The Parameter section allows for user adjustment of the internal heater PID parameters to account for local extreme conditions. The default values (Gain 0.40, Integral 00.45min and PWM 5.0sec), will handle 95% of all installations. CONSULT Factory before adjusting.

The Temp Cal parameter provides an offset of the actual measured return air sensor of the cabinet. It can be adjusted up to +/- 5Deg to accommodate local applications and cabinet conditions (default Value is 0).

Maintenance Screen

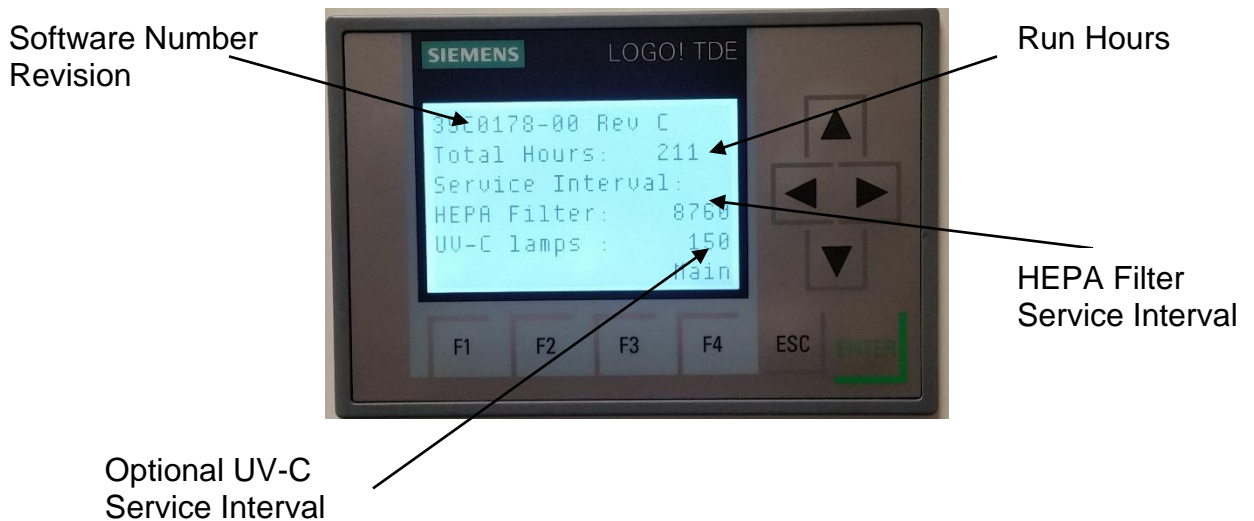

Software Number
Revision

Run Hours

HEPA Filter
Service Interval

Optional UV-C
Service Interval

The Maintenance screen displays the total run hours of the cabinet and provides (2) service timers. The timers monitor the service life of the HEPA filter and optional UV-C lamps. A service warning (Orange screen) is generated when 150hrs of service remains and an Alarm (Red Screen when past due). Once the HEPA filter or UV-C lamps are replaced, the service timers can be reset. The default value is 8760 hrs for the HEPA filter and 0 hrs for the UV-C lamps. Both service times can be field adjusted.

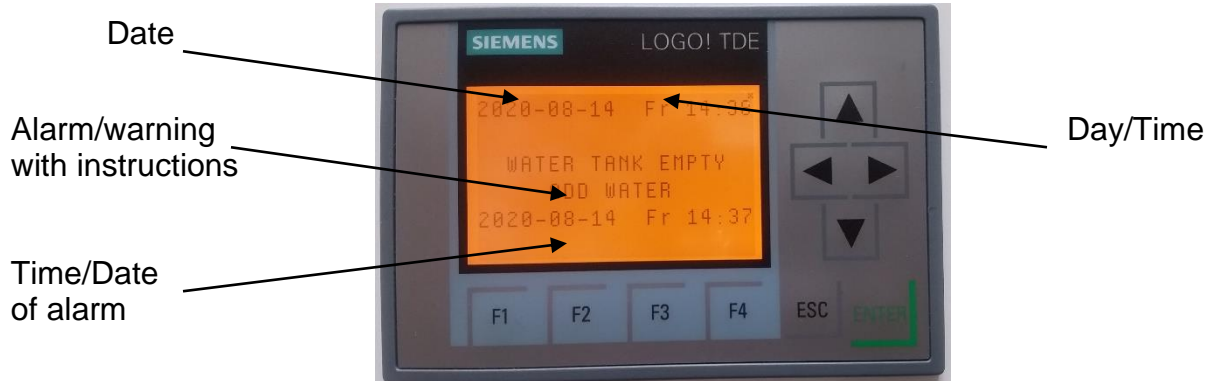
Warning Screen-ORANGE (Typical)Alarm Screen-RED (Typical)

When a Warning or Alarm occurs, the screen will change color, Orange for a warning and Red for an alarm. The condition of the unit will be displayed, along with the time of the event and recommended resolution.

To set Time and Date

Depress the DOWN arrow key, then ESC Key, select Logo Settings, select SETUP, select CLOCK, select SET CLOCK. The time and date can now be entered. Use the ESC Key to back out to the main screen. Use the Arrow keys to scroll and Enter key to accept changes.

8.0 Keyless Lock

The SSC4500DX is supplied with a keypad style lock to protect the contents of the cabinet. The lock can be opened by typing the MASTER code of 11335577 or the USER code of 2244. These codes can be changed for local use.

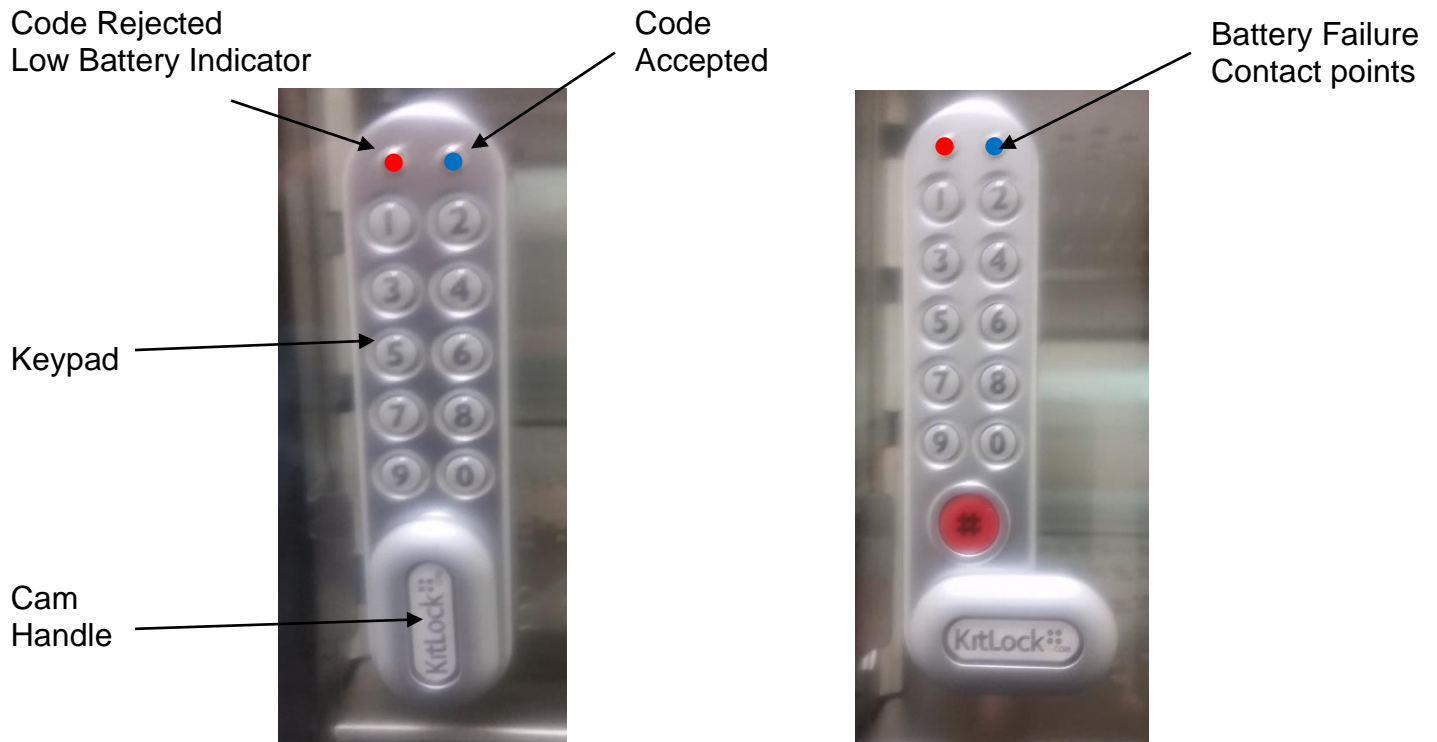

Figure: 10 Locked

Figure: 11 Open

2) Programming/Changing code:

- a) To program, the lock must be in the open position with the # button visible. Every program command must commence by pressing the # button, followed by either the Master code or user code.
- b) #Master code • 01 • New Master Code • New master code ••
Example: #11335577 • 01 • 12345678 • 12345678 ••
- c) #Master code 02 User Code
Example: #11335577 02 9999

3) Battery Replacement: The lock should provide well in excess of 15,000 openings of 4 seconds each from two (2) AAA 1,5V batteries. To fit new batteries, remove the upper fixing bolt and swing the lock downward over the edge of the door. Replace the batteries and refit the lock. Dispose of used batteries properly.

4) Emergency Override: If the batteries should die between maintenance cycles, the

lock can be overridden.

- a) Place the contact points of a 9Volt battery against the contact points surrounding the Blue and Red LED's.
- b) Place the positive battery terminal against the RED led and the negative battery terminal against the BLUE led.
- c) Enter the master code.
- d) The motor will withdraw the locking pin, allowing the lock to be opened.
- e) Install new batteries. Dispose of used batteries properly.

IMPORTANT LOW BATTERY:

When the battery power is low the RED LED will flash (3) times before the BLUE LED light, accepting the code. Replace batteries as soon as this happens. The lock will operate for 100 times with low battery.

Control Panel

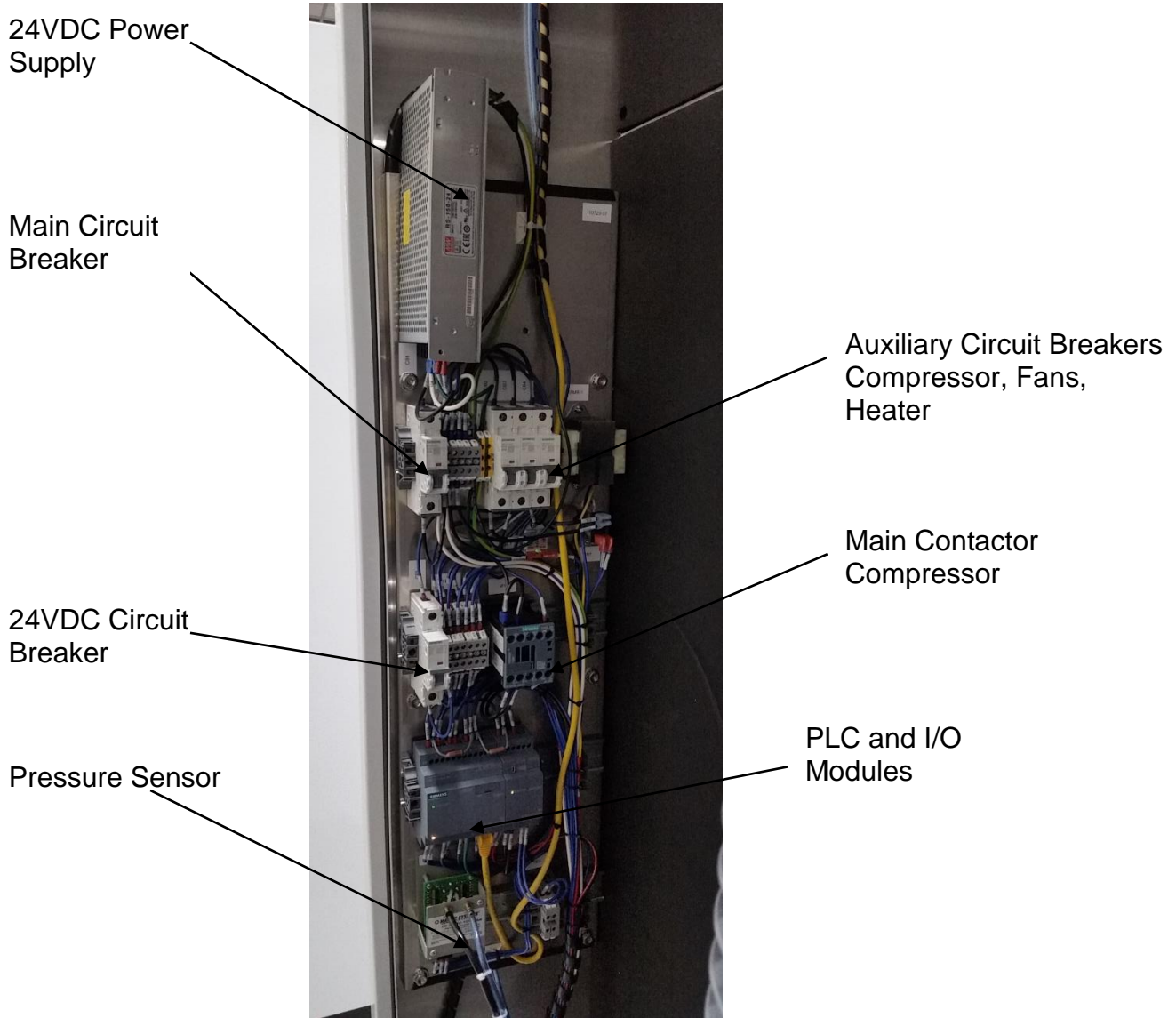

Figure: 12 Control Panel Configuration

9.0 Field Terminations

There are several standard and optional outs for transmitted remote information.

Standard

- a) Alarm Relay: Normally open form C
Terminal Block #3, #1 and #2.

Optional

The temperature, humidity, and cabinet values can be retransmitted with a 0-10VDC signal scaled as shown.

- a) Pressure: 0-10VDC Conversion: $In-H_2O = (VDC * 25) - 2500$
Terminal Block #3, #3 (pos), #4 (neg)
- b) Temperature: 0-10VDC Conversion: $Temp\ ^\circ F = (VDC * 25) - 5$
Terminal Block #3, #5(pos), #6 (neg)
- b) Humidity: 0-10 VDC Conversion: $RH\% = (VDC * 25) - 25$
Terminal block #3, #7(pos), #8(neg)

10.0 Maintenance

Item	Weekly	Monthly	Yearly
Verify temp/RH meet setpoint	X	X	X
Clean cooling air filter		X	X
Change HEPA filter			X
Check power cord damage			X
Change keyless lock batteries			X
Change UV-C bulb	Per Service Timer		
Change UV-C deflectors -Every two years			**Note
Change vapor supply tube			X

Spare Parts List	Part #
HEPA Filter	#74C0195-00
UVC-E Light Tubes (2 required)	#XXXXXX
Filter Media Part	#74C0196-00

Other Items	Part #
Water Solenoid	#52H0028-00
Vapor Supply Tubing (2 ft)	#54C0576-01
Water Tank with Pump	#19C0182-00
Gravity Fill Port	#19C0083-00
Humidifier Assembly	#93C0275-00
Refrigeration Cassette	#99C0185-00
Shelf	#71C2645-00
Keyless Door Lock	#11C0245-00

Cleaning:

- 1) Keep payload of cabinet clean with a disinfectant suitable for use with stainless steel. Wipe as deemed necessary.
- 2) Inspect water reservoir and replace as needed to prevent microbial growth. All water which travels through the water storage reservoir and supply lines is boiled into steam before being introduced to the payload of the cabinet.
- 3) Wipe exterior of cabinet with a soft cloth and any standard cleaner.
- 4) Remove back panel and vacuum any dust accumulation from the refrigeration cassette coil and the inlet air filter, make sure cabinet is unplugged prior to removing the back panel.

1) Refrigeration Cassette

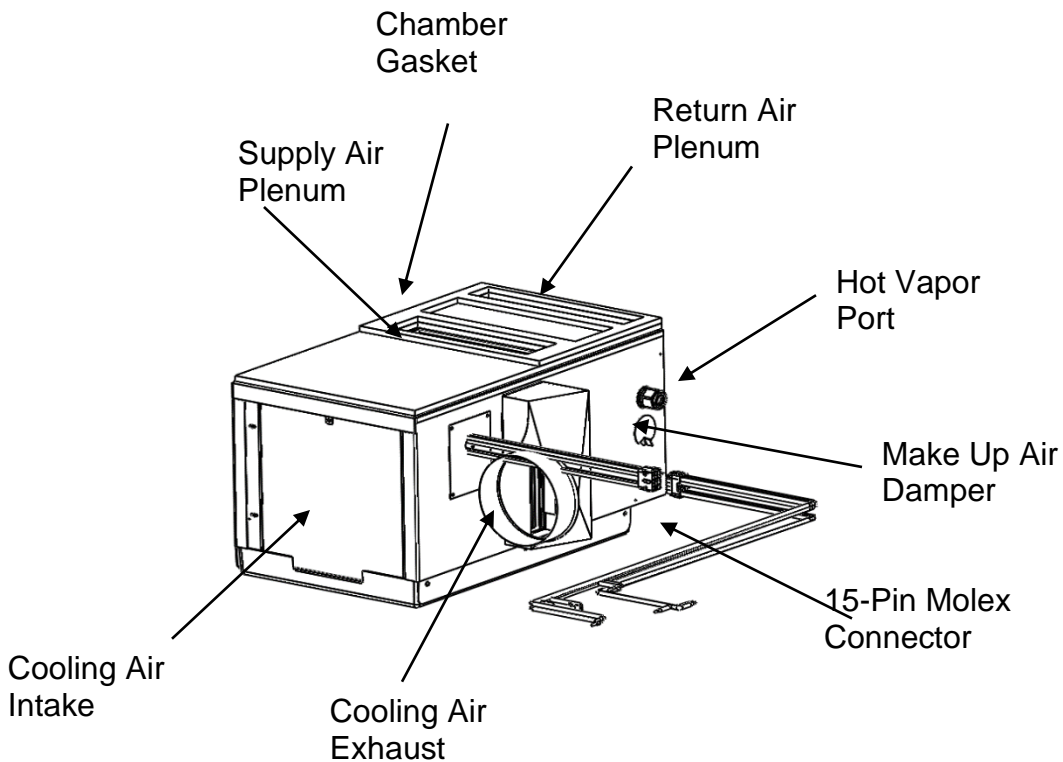

Figure: 13 Refrigeration Cassette

The Refrigeration cassette was designed to be easily removed for service or replacement.

- Unplug the unit from the wall and move it to a safe workspace.
- Remove the rear cover with a screwdriver by turning the (4) cam locks.
- Remove the lower cover by removing the (2) rear bumpers with an Allen wrench and the rear panel by removing the (4) bolts with a 7/16" wrench.
- Unplug the white 15-pin Molex connector.
- Remove the waste heat ductwork from the cassette plenum, it slides out no fasteners required.
- Remove the vapor supply tube to the cassette.
- Remove the refrigeration cassette bracket.
- Remove the wing nut securing the cam handles.
- Pull the upper cam handle towards the rear of cabinet, lift and rotate the lower handle toward the front of the cabinet.
- The cassette is now free to slide out.

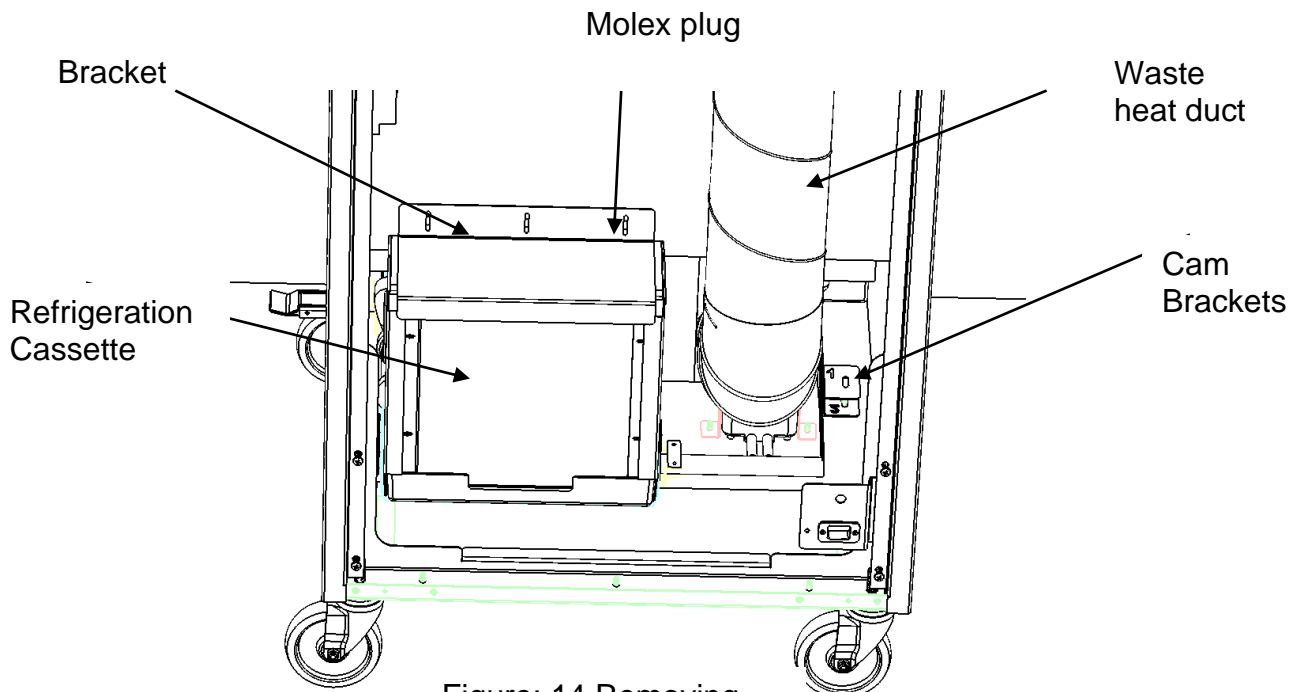

Figure: 14 Removing Refrigeration Cassette

To reinstall the cassette, reverse the steps above.

2) HEPA Filter and Optional UV-C Light

The HEPA filter should be replaced on a yearly basis along with the optional UV-C light tubes.

- Unplug the unit from the wall and move to a safe workspace.
- Remove the rear cover with a screwdriver by turning the (4) cam locks.
- Unplug the Molex connector protruding through the cover (only if UV light option is installed).
- Using a 3/8" wrench, remove the HEPA Filter cover.
- Remove the wing nuts and Brackets holding the filter in place.

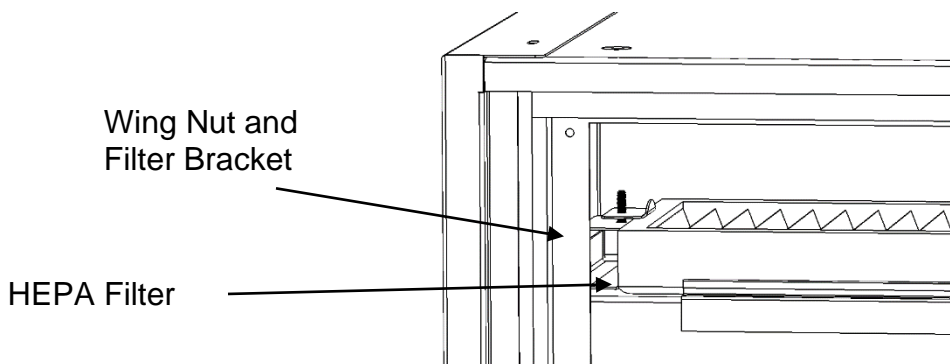

Figure: 15 Removing HEPA Filter

-Remove the HEPA filter and replace with a new filter. DO NOT touch the filter media and verify that it is not damaged.

UV-C option only

- Loosen the compression fitting holding the light tube.
- Gently pull the bulb from the socket.
- Replace the new bulb. Make sure the pins are seated in the ballast and tighten the compression fitting.

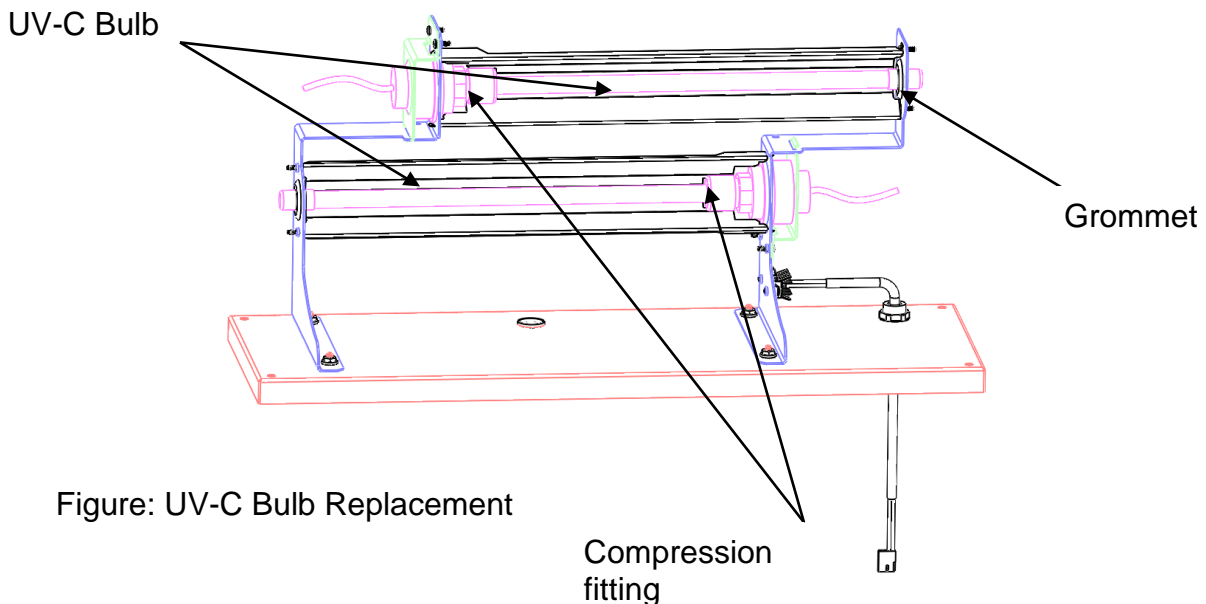

Figure: UV-C Bulb Replacement

Figure: 16 UV-C Light Assembly

- Replace the Filter panel access door.
- Replace the bolts and tighten.
- Plug in the Molex connector.
- Replace the rear cover of the unit.
- Plug the unit into wall outlet.

3) Cooling Air filter

The unit needs cooling air, which is drawn in from the rear bottom surface of the unit and discharged at the top. The inlet air is protected by a filter media that needs to be inspected and/or cleaned monthly and replaced on a yearly basis.

- a) -Unplug the unit from the wall and move to a safe workspace.
 - Remove the rear cover with a screwdriver by turning the (4) cam locks.
 - Remove the filter media. It is flexible and can be compressed to facilitate removal.
- b) -Inspect the filter for dirt dust and debris.
 - Inspect the filter media for damage.
 - The filter media can be rinsed with tap water and dried prior to installation.

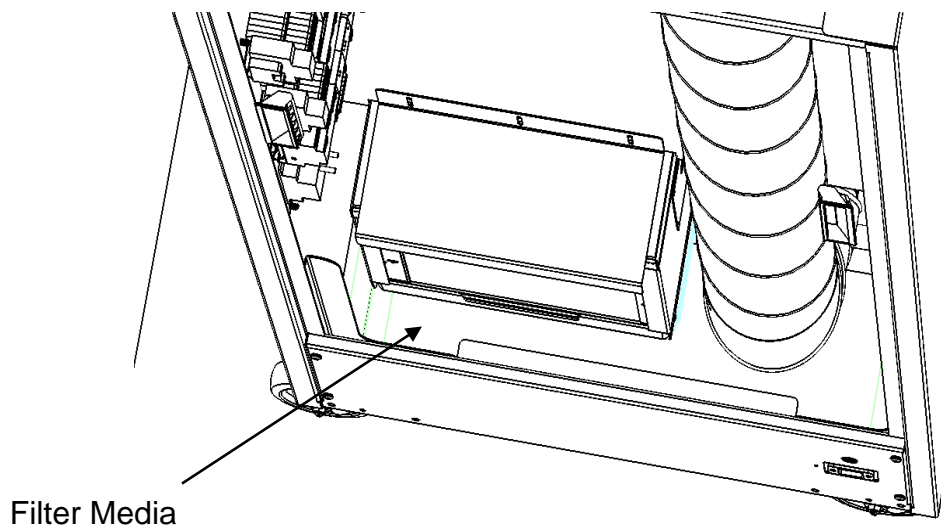
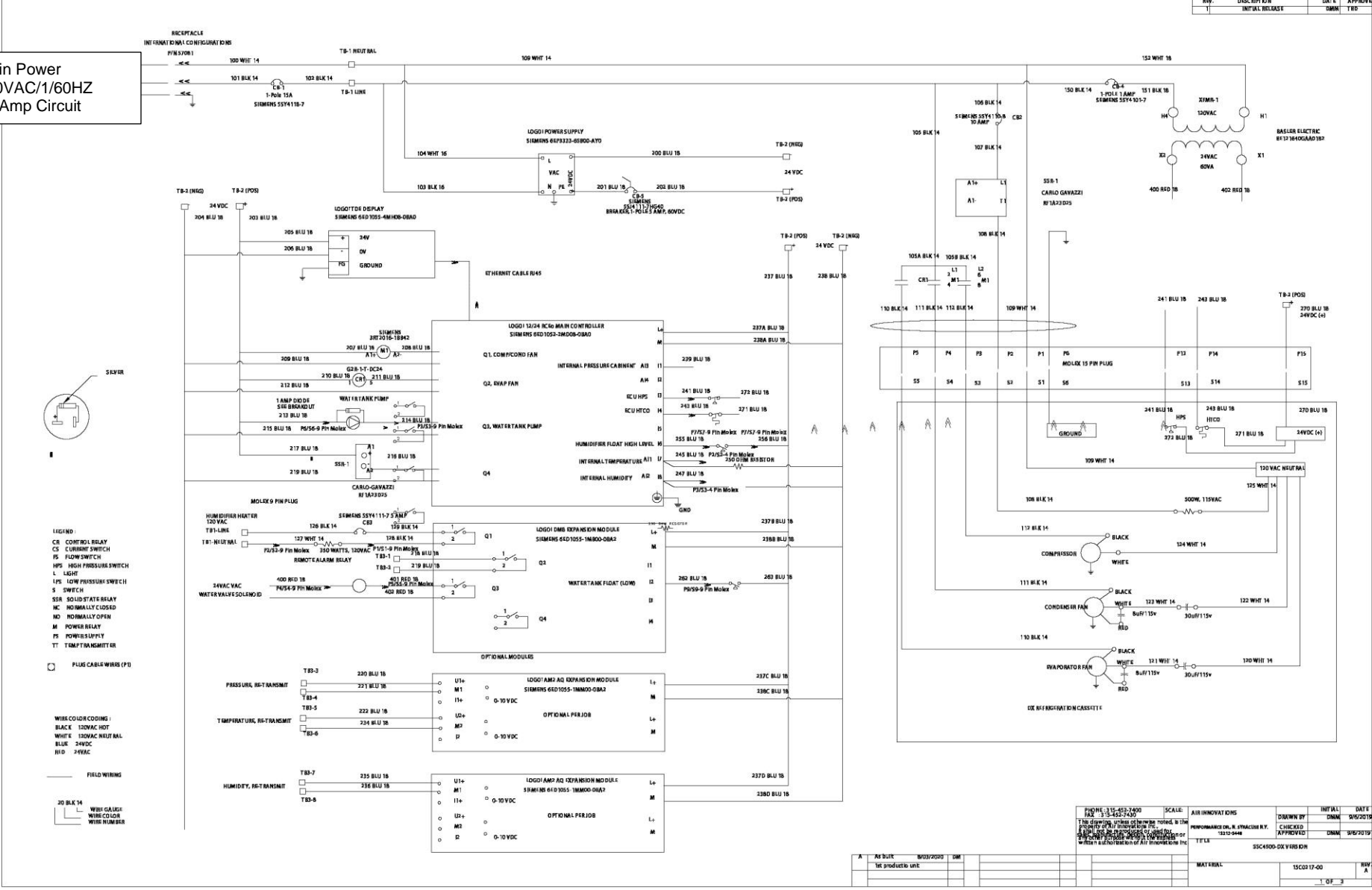

Figure: 17 Removing Cooling Air Filter

Main Power
120VAC/1/60HZ
15 Amp Circuit

REV.	DESCRIPTION	DATE	APPROVED
1	INITIAL RELEASE		



PHONE	FAX	SCALE	AIR INNOVATIONS	DRAWN BY	INITIAL	DATE
914-853-7400	914-853-7400	1:1		DMN		06/2019

THESE DRAWINGS ARE THE PROPERTY OF AIR INNOVATIONS. NO PARTS OF THESE DRAWINGS ARE TO BE REPRODUCED OR TRANSMITTED IN ANY FORM OR BY ANY MEANS, ELECTRONIC OR MECHANICAL, INCLUDING PHOTOCOPYING, RECORDING, OR BY ANY INFORMATION STORAGE AND RETRIEVAL SYSTEM, WITHOUT THE WRITTEN PERMISSION OF AIR INNOVATIONS.

AIR UNIT	REV	DATE	DM	REV
SSC4500DX	0001/2020	DM		1

TITLE: SSC4500DX WIRING

MATERIAL: 15C0233-00

REV	DESCRIPTION	DATE	APPROVED
1	RELEASED		DMW/TBD

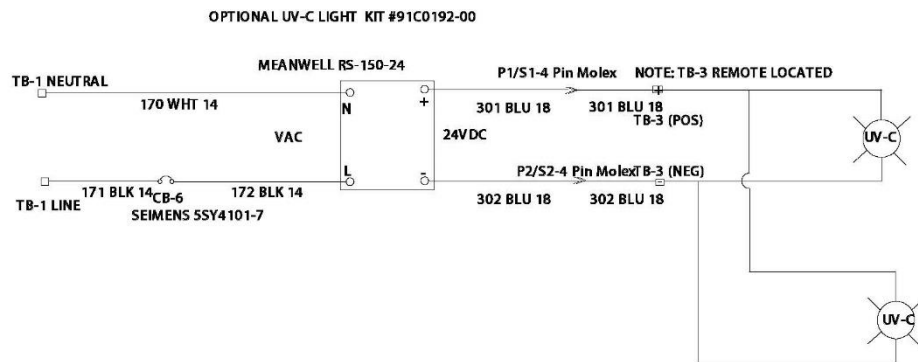
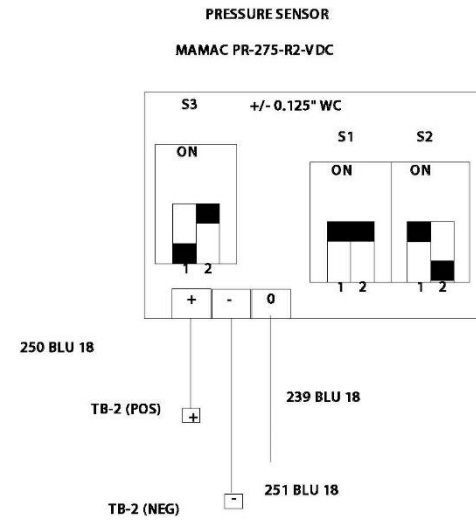
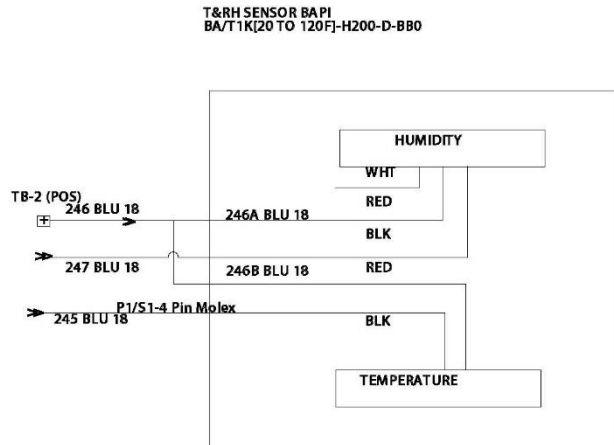

PROJ: 15C0233-00	SCALE:	AIR INNOVATIONS	DRAWN BY: DMW	INITIAL:	DATE: 9/9/2019
P/N: 15C450DX		PERFORMANCE, INC.	CHECKED:		
<small>This drawing, unless otherwise noted, is the property of Air Innovations, Inc. It shall not be reproduced or used for any other purpose without the written authorization of Air Innovations, Inc.</small>					
TITLE: SSC4500-DX VIBRATION					

MATERIAL:	15C0233-00	REV: A
		2 OF 3

11.0 Troubleshooting

Issue	Possible Cause	Resolution
Temperature not holding set point	a) Wrong set point b) Is the heater circuit breaker tripped c) Has the door been open for extended time d) Temperature Sensor offset required	a) Verify that set point is proper value b) Reset heater circuit breaker c) Verify door is closed and let unit stabilize for 1-hour d) Increase or Decrease Temp Calibration on Parameters screen
Internal Pressure Alarm	a) Is the door closed and sealed b) Is the external vent tube blocked/plugged c) Lower Alarm Limit	a) Verify door is closed and let unit stabilize b) Clear/unblock pressure tube near electrical connection
Low Humidity	a) Is there water in the tank b) Has door been open for extended time c) Has the humidify circuit breaker tripped	a) Add water until b) Verify door is closed and let unit stabilize for 1-hour c) Reset humidifier circuit breaker
Blank Display Screen	a) Does unit have power b) Are the RJ45 cables connected (both ends) c) Is the 24VDC circuit breaker tripped	a) Verify supply power b) Verify RJ45 cable seated at both ends c) test for 24VDC power at terminal blocks and reset 24VDC circuit breaker
Keyless lock not responding	a) Wong security code b) Expired batteries in lock	a) Use master code to open and reset keyless lock b) Use emergency open procedure and change batteries.

12.0 Warranty

GENERAL

Air Innovations warrants, to the original buyer, its goods and all parts thereof to be free from defects in material and workmanship for one year from the date of invoicing assuming **NORMAL USE AND SERVICE**.

LIABILITY

Air Innovations liability shall be limited to the repair or replacement (at its option) of any part, which, at our sole discretion, is determined to be defective. The purchaser shall pay all transportation costs. Additionally, if a malfunction occurs within 90 days from the date of invoice, **Air Innovations** will reimburse the reasonable cost of labor required for the repair or replacement provided authorization is obtained from one of our authorized representatives prior to incurring any labor charges.

LIMITATIONS OF LIABILITY

THESE WARRANTIES ARE MADE IN LIEU OF ALL OTHER WARRANTIES EXPRESSED OR IMPLIED, INCLUDING ANY IMPLIED WARRANTY OF MERCHANTABILITY OR FITNESS FOR A PARTICULAR PURPOSE AND IN LIEU OF ANY OTHER OBLIGATION OR LIABILITY, INCLUDING LIABILITY FOR ANY INCIDENTAL OR CONSEQUENTIAL DAMAGES. **Air Innovations** will not be responsible for any costs or liabilities whatsoever resulting from improper installation or service of its equipment. In the event that **Air Innovations** or its distributors are found liable for damage based on any defect or nonconformity in the products, their total liability for each defective product shall not exceed the purchase price of such defective product. Additionally, neither the repair nor the replacement of any part shall serve to renew or extend the original warranty period. No person or representative is authorized to change these warranties or assume any other obligations or liabilities for **Air Innovations** in connection with the sale of its systems.

INDEMNIFICATION

Purchaser agrees to indemnify, hold harmless and defend seller and its officers, directors, agents and employees from and against any and all claims, liabilities, costs and expenses arising out of or related to Purchaser's use of the goods, or in any way involving injury to person or property or accident occasioned by the goods sold by **Air Innovations** to Purchaser.

FOREIGN GOVERNMENT AND INDIAN NATIONS

If Purchaser is a foreign government or an Indian nation, Purchaser hereby expressly waives its defense of sovereign immunity in the event of a dispute between Purchaser and **Air Innovations** regarding this invoice and Purchaser expressly acquiesces to the jurisdiction of the federal and state courts of the United States.

SEVERABILITY

If one or more of the provisions contained in this contract shall for any reason be held to be invalid, illegal or unenforceable in any respect, such invalidity, illegality or unenforceability shall not affect any other provision of this contract, but this contract shall be construed as if such invalid, illegal or unenforceable provision had never been contained.

ADDITIONAL REQUIREMENTS

If a defect covered by the Warranty occurs, contact **Air Innovations** for authorization to proceed with corrective action. Do not return any parts or incur any charges for which you expect to be reimbursed under this Warranty without receiving this authorization. If parts are replaced under this Warranty, the defective parts must be returned prepaid within 30 days. This Warranty shall be null and void in its entirety if the Serial Number on the air conditioner or compressor is altered, removed or defaced.